

Rubber Molded End Filters



- **Rugged Rubber End Seals**
- No Bypass. No Cracking w/Age.
- **Textile Media** - Not Paper
- Handles Moisture, Vibration, Abuse.
- **Genuinely Cleanable**
- Practical & Economical
- **Exceptional Performance**
- Lower ΔP , Longer Life

Rubber Molded End Style - Cylindrical, double open ends (DOE) of polyurethane rubber, perforated or expanded metal center core, pleated textile, or wire screen filter media. ODs 3" -36", OVHTs 2" - 40", Pleat depths from 0.5" - 4.25". These are arguably the finest built, self sealing, low micron, low ΔP , high flow, field cleanable, and fool proof filter elements available today.

More than 50 years ago, molded end filter elements challenged the worst of punishments in industrial and military services. Today, with synthetic rubber ends, they are arguably the finest air/gas filters ever made.

We manufacture a broad range of sizes ... Overall heights to 40", outside diameters to 36", and inside diameters from 1" to 30". (If you need larger, please call for specific information.) They can handle air/gas flows to 20,000 CFM. Some provide particle retentions down to 99.9% at 0.1 μ (micron).

These molded end filters are cylindrically shaped. They are designed to cover an intake opening, being held in place by a reuseable plate fitting over a center rod assembly. They have solid rubber ends, heavy duty perforated mild steel, 304SS or 316SS center cores, and radially pleated filter media jacketed with woven wire screen. This screen jacket holds fins open, greatly improving flow and life. Their textile media are well known for superior performance

and cleanability vs. fragile paper media. This rugged construction has been long proven to yield higher flows, longer life, and lower ΔP !



New urethane rubber molding systems yield superior filter end seals at production run economy. Don't settle for PVC ends that can soften at intermittent elevated temps., or crumble if undercured.

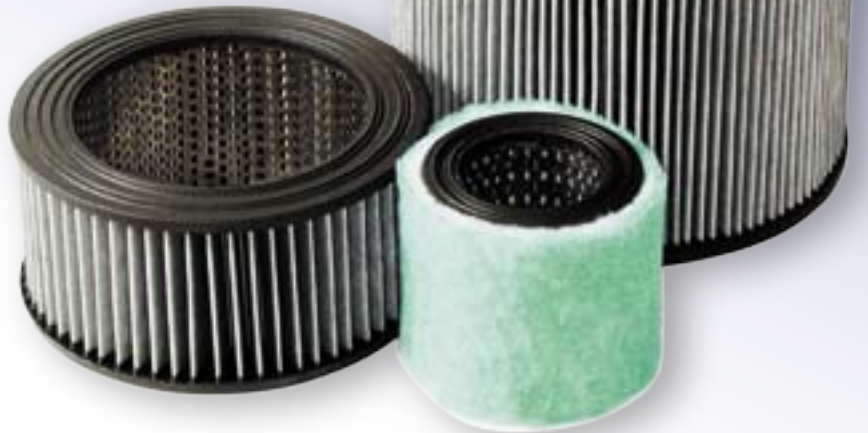

Rubber Molded Ends.

The filter media, support screens, and element cores are bonded together by synthetic rubber ends. Rubber is much more rugged and durable than lesser polyvinyl elastomers used by others. Rubber will not crumble in service as undercured PVC can. PVC is as much as 50% plastisizer. When this plastisizer evaporates, PVC ends can crack and fail. Our standard synthetic rubber ends are black. We offer colored rubber as well, such as white for food service applications.

We carve production molds from solid stock (no stampings) for exacting end seals. These seals stop dirt cold, and resist most oils and solvents, moisture, or vibrational punishment. They can withstand continuous service to 250° F, and

intermittent service at 350°F*. Optional Silicone rubber ends can serve to nearly 500°F.

**Performance considerations vary with elevated service temperature and environments. Metal end options with high temp potting materials can serve to over 2000°F.*

An Element's Core Is Its Heart.

A filter with a weak center core is a house built of straw. We routinely use 16 and 20 gauge perforated steel with 58% open area for low ΔP and high column strength to support the innermost end seal. We weld metal core seams and use premium corrosion inhibitors that will not flake off as paint can. These elements are designed to stand up to abuse.

Standard End Seal

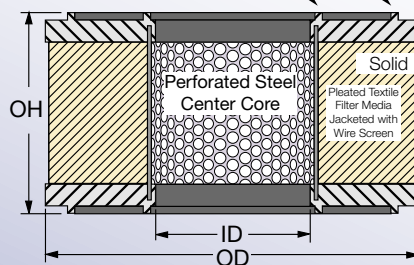

This standard end seal employs one or typically two narrow raised circular sealing surfaces. The center most seal usually stands directly above the center core, ensuring column strength is passed along to the seal when installed in service.

"IR" End Seal

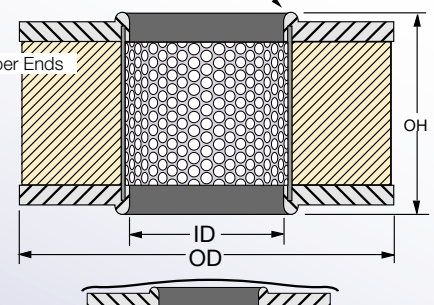

This end seal employs a single raised sealing surface directly above the center core at the very inside diameter of the filter. When the lid of a filter housing has a domed cross section, the IR seal is occasionally necessary to avoid a fit conflict at the shoulder.